

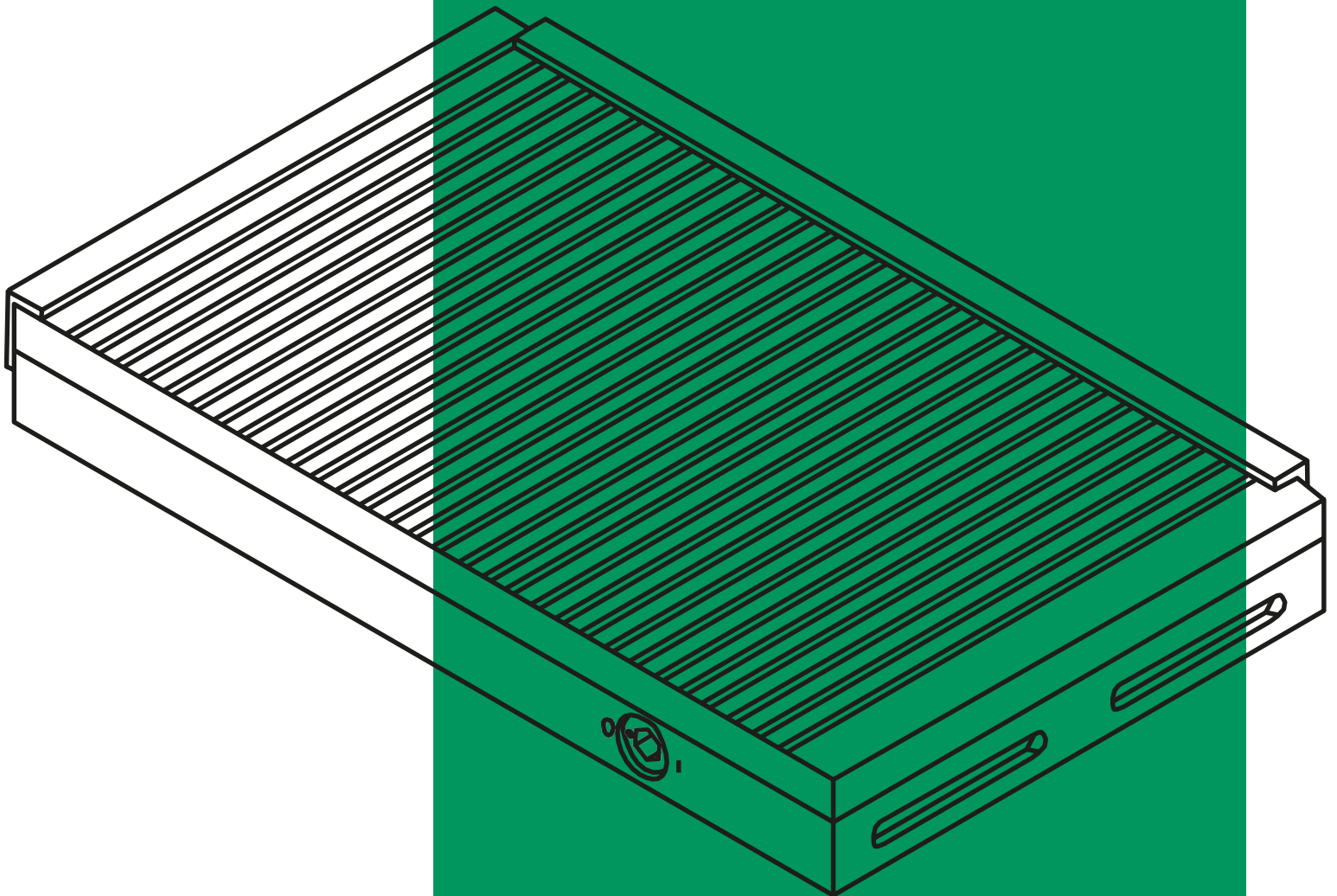

Magnetic Products, Inc.  
Highland, Michigan | [mpimagnet.com](http://mpimagnet.com)

# OPERATION AND SAFETY INSTRUCTION MANUAL

# MPI Rare Earth Compact Milling Chuck





# OPERATING AND SAFETY INSTRUCTION MANUAL FOR MPI RARE EARTH COMPACT MILLING CHUCK

## WELCOME

Thank you for purchasing an MPI Rare Earth Compact Milling Chuck. The Operation and Safety Instruction Manual contains all the information required for safe and optimum use of the chuck. Please read the instructions carefully and follow the directions.

On delivery, check that the chuck has been delivered not damaged or defective. Contact your supplier immediately if you find the product is damaged and/or defective.

The model number is located on the on the side of the chuck. Document the model number for future correspondence. Keep the model number and instructions in a safe location close to the workplace.

## WARRANTY

The warranty term is one (1) year from date of delivery. Warranty covers any manufacture or material defects. Warranty does not cover failures due directly or indirectly listed below:

- + Failure to comply with these operating and maintenance instructions.
- + Use other than being considered as normal.
- + Normal wear and tear.
- + Modifications or repairs not performed by MPI or an authorized party.

## INTRODUCTION

This type of magnetic chuck is a manually operated permanent magnetic chuck. It is turned ON or OFF by turning the actuator shaft 180 degrees by means of an allen key.

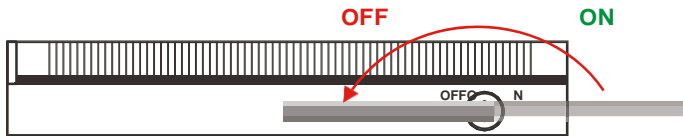

While working, the chuck is independent of any external power supply, thus offering:

- + Safety, by constant holding power.
- + Accuracy, no heat development causing expansion.

The use of so-called Neodymium magnets provides you with a high holding force and still a good deal of force in difficult situations. Thanks to the micropitch pole division, very small components can be held.

## THE MPI COMPLETE DELIVERY

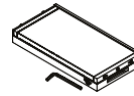

MPI RARE EARTH COMPACT MILLING CHUCK AND AN ALLEN KEY



OPERATING AND SAFETY INSTRUCTION MANUAL



TEST AND INSPECTION CERTIFICATE

## INSTALLATION PROCEDURE

The magnetic chuck is to be secured to the machine table according to the following installation procedure.

**THE TOP AND BASE PLATE OF EVERY MPI CHUCK ARE GROUND ACCURATELY FLAT AND PARALLEL BEFORE SHIPPING. NEVERTHELESS, AS DAMAGE DURING TRANSPORT, UNPACKING AND HANDLING CANNOT BE ENTIRELY EXCLUDED, WE RECOMMEND THAT THE CHUCK BE CAREFULLY INSPECTED.**

1. Check flatness of machine table. Correct machine geometry if necessary. Check aspect of magnetic chuck. Grind base plate of chuck first. This must be done without any stress. Place the chuck upside down on the machine table and block each end to prevent the chuck from moving during grinding. Shim as necessary. **DO NOT HOLD IN PLACE BY TURNING ON CHUCK!** Grind the surface until flat using adequate coolant flow. Let the chuck cool down and check the flatness. Repeat if necessary.
2. Clean the chuck thoroughly freeing from all burrs. Clean machine table as well and apply a rust preventative on both table and base plate of chuck. Mount the chuck in the normal upright position. Clamp tight at one end and only finger tight at the other. This will allow for expansion without distortion as the installation reaches its normal working temperature.
3. Turn on the chuck by turning the actuator shaft in the direction indicated on the tag or body. Using normal coolant flow, allow machine and chuck to stabilize at normal working temperature.
4. Grind the workholding surface perfectly flat. Use the highest table speed at the final cut. Check flatness. Repeat finish cut if necessary.

**EACH TIME THE CHUCK IS GROUND, THE WHEEL SHOULD BE TRUED. A "COMMERCIAL" GRIND FINISH WILL PROVIDE THE BEST COEFFICIENT OF FRICTION FOR NON-SLIP MAGNETIC HOLDING OF WORKPIECES ON THE CHUCK.**



## SAFETY PRECAUTIONS

- + Do not operate the magnetic chuck until you have read and fully understood this manual.
- + The magnetic chuck generates a magnetic field concentrated above the clamping surface. Equipment, sensitive to magnetic fields, must not be allowed to come in close proximity to the chuck when switched on:
  - Heart pacemakers keep four (4) feet distance.
  - Data storage devices like magnetic tape cassettes, floppy discs, credit cards etc.
  - Watches, reed relays or similar.
- + The magnetic field exerts a high force to a ferrous object held close to the chuck's clamping surface:
  - As a general rule, do not magnetize the chuck without the workpieces being in place.
  - Never put your fingers between the workpiece and the clamping surface.
- + Always wear protective goggles during machining, particularly during dry grinding.
- + Check that all protective guards are correctly positioned before machining begins.
- + The magnetic properties of the workpieces should be checked before machining starts. Some types of steel are completely non-magnetic, others have reduced magnetic properties.
- + Always check the stability and holding capacity of the arrangement of workpieces placed on the chuck.



## MAGNETIC WORKHOLDING

A good understanding of the fundamentals of magnetic workholding will allow you to get the maximum performance from your magnetic chuck and avoid accidental damaging of perhaps expensive workpieces.

### 1. Pole configuration and magnetic area of your magnetic chuck

Your magnetic chuck typically has long, narrow steel strips running cross- or lengthwise. These are called "poles". Your workpiece(s) must cross these poles in order to make contact with North and South poles and close the magnetic circuit. This ensures a proper magnetization of your workpiece(s) and thus a good holding force. It is not always obvious to identify North and South poles, therefore it is recommended to cross as many steel strips as reasonably possible. Narrow workpieces placed parallel to the poles and touching only one pole will not be clamped adequately. In such cases consult your local supplier or the manufacturer directly if possible. Some areas may have a lower holding force like the short ends or along the long sides of your chuck. Bigger workpieces with sufficient contact area will not present problems, but small pieces should be kept away from these areas. Use packing pieces between the side and back stops and your small workpieces.

A unique feature of an MPI Rare Earth Compact Milling Chuck is the fact that the holding force at the left end starts almost immediately at a very high level!

### 2. Workpiece dimensions and shape

As explained before your workpiece(s) must touch North and South poles. If the shape and/or size of your workpiece(s) does not allow for a proper contact you may have to use auxiliary laminated blocks. MPI has a wide range of such blocks and plates. The bigger the contact area, the higher the holding force. Please refer to the Application Data Sheet for workpiece details.

Also, the thicker the workpiece, the more magnetic flux it can absorb and the more holding force will be generated. Refer to the Performance Data on the Application Datasheet. You can use packing pieces to block workpieces with a limited contact area or nest smaller pieces together to create a bigger contact area. These packing pieces should have a thickness suitably less than that of the workpiece and the contact surface should be finish ground.

### 3. Workpiece surface condition

Magnetic force lines flow from North to South poles through the workpiece. They do not like to flow through air or nonmagnetic materials. A bad surface condition like a rough surface or rust or an untrue surface will create an airgap thus reducing the holding force. Flat, smooth and clean workpieces will achieve the highest holding force. Therefore deburr your workpieces and file away shock marks if necessary.

Always keep your chuck's clamping surface clean and redress if the surface is scratched badly or damaged. Refer to the Performance Data for details.

### 4. Workpiece material

Low carbon mild steel (St37) presents the best magnetic properties. Tool steels, containing elements like chromium, molybdenum, nickel, vanadium have reduced magnetic properties and even less than 40% or 50% in hardened condition depending on the type of chuck you have. Refer to the Performance Data for details. In case of problems holding hardened tool steel, ask your supplier for advice.

## MAINTENANCE

- + Keep the surface of your magnetic chuck in perfect condition. Use a stone to remove any imperfections. In case of more serious damage, deep scratches, shock marks, redress the surface of your chuck as described in point 4 of the Installation Procedure.
- + There is one important environmental requirement to ensure the longevity of your magnetic chuck. If you are using your chuck in wet machining applications, the pH level of the coolant must be 8.7 or higher. Extended use of your chuck below pH 8.7 may result in premature repair as a result of corrosion of the metals in the top plate.



## RETURN AND REPAIR INSTRUCTIONS

Contact your supplier for all warranty and non-warranty related repairs on your magnetic chuck. A return authorization with any applicable shipping instructions will be issued. After receipt of the products to be repaired, MPI will perform an inspection and provide an estimate of the repair cost at no charge to the customer. Authorization from the customer must be obtained by MPI before repairs are made. Transport charges, both to and from the factory, are solely the responsibility of the customer.

### MAGNETIC CHUCK APPLICATION DATA

TYPE OF CHUCK: PERMANENT

MODEL: MPI RARE EARTH COMPACT MILLING CHUCK

CONTROLLER: n.a.

MAIN APPLICATION: Workpiece grinding on surface grinding machines

### DIMENSIONS AND DISPOSITIONS OF WORKPIECES

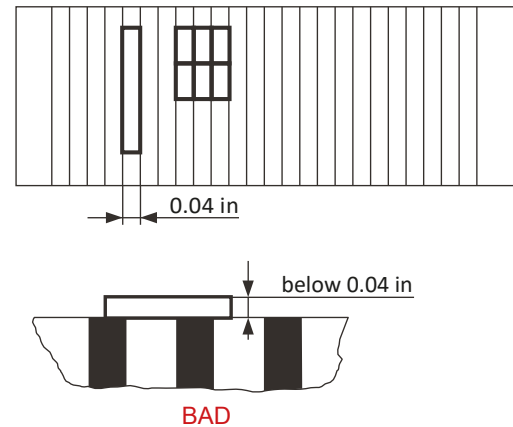
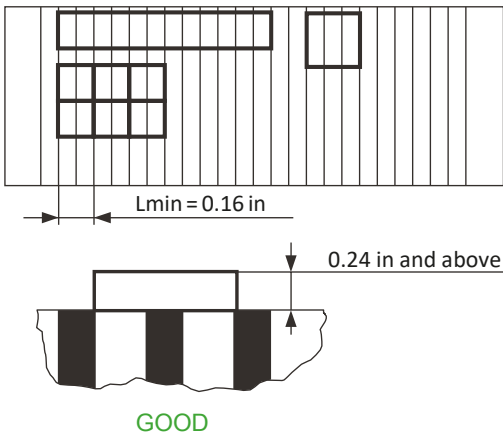

### PERFORMANCE DATA

WORKPIECE AREA

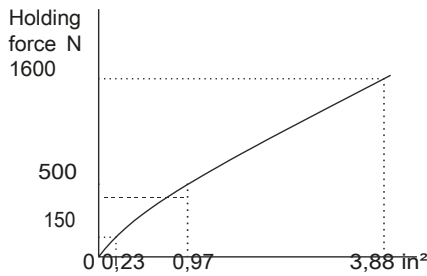

WORKPIECE THICKNESS

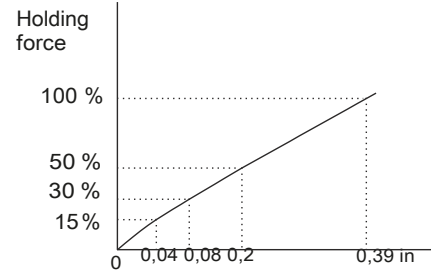

SURFACE QUALITY

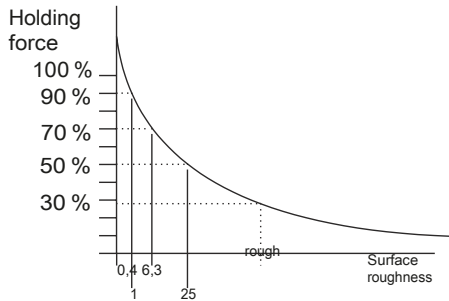

MATERIALS

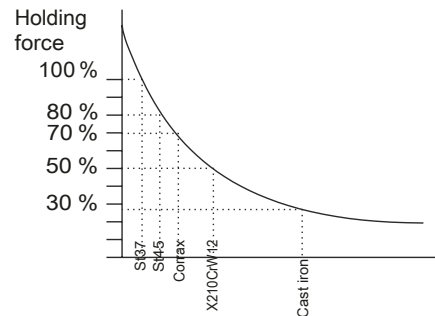

MPI reserves the right to change any components, details, and accessories considered necessary for the improvement of this magnetic device, or for production or commercial purposes, without updating the Operation and Safety Instruction Manual.

© Copyright 2019: All rights reserved. No part of this publication may be duplicated and/or made public by means of printing, photocopying, microfilm or in any other manner whatsoever without prior written permission from MPI. This also applies to all accompanying drawings and illustrations.



---

[mpimagnet.com](http://mpimagnet.com)